

Distributed by:



**Corrosion  
Control  
Equipment  
and  
Supplies**

**Houston Office:**  
248 McCarty Dr.  
Houston, TX 77029-1195  
(713) 672-8251  
Fax (713) 672-6636

*1-800-CLEMTEX*  
*www.clemtex.com*  
*clemtex@clemtex.com*

**Dallas Branch:**

4770 Gretna  
Dallas, TX 75207  
(214) 631-0584  
Fax (214) 631-5824  
1-800-BLAST 97

**Corpus Christi Branch:**

4750 Westway  
Corpus Christi, TX 78408  
(361) 882-8282  
Fax (361) 882-6029



## BNP-6012 & 7212 Mini Blast Rooms - Suction System

New Models replace  
BNP 600 & 720  
effective Fall 2012



**Clean  
Peen  
Deburr  
Finish**

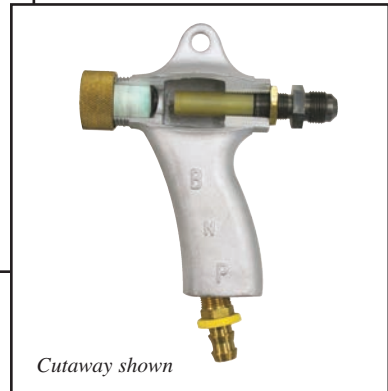

Cutaway shown

Model BNP-6012 S with 900 CFM Reclaimer and Reverse Pulse Collector

**BNP 6012 & 7212 Mini Blast Rooms deliver efficient, affordable media blasting to clean, peen, deburr, or finish parts.**

New— bolt-on sump pipes and pipe adaptors, and dimensional changes that affect curtain sizes.  
**CAUTION:**  
Curtain sizes differ; take care when ordering replacement curtains or alox kits for older 600 and 720 models.

- Common Applications**
- Remove rust, mill scale, heat scale, and carbon buildup from metals
  - Strip paint, powder coating, plating, and anodizing from parts for rework
  - Eliminate burrs, parting lines, flashings, and other defects from castings and injection-molded parts
  - Extract residual sand from castings
  - Beautify steel, stainless steel, aluminum, brass and other metals with a uniform matte finish
  - Etch artwork and lettering into glass, stone, plastics, metal and other materials
  - Clean release agents and material buildup from molds

**BNP 6012 & 7212 Suction Cabinets Feature:**

- Safety**
- ✓ Full-length, neoprene-on-fabric gloves resist wear and protect operator.
  - ✓ Ceiling-mounted, four-tube fluorescent light fixture with abrasive resistant wire-embedded glass cover for extraordinary visibility.
  - ✓ Safety interlocks interrupt blasting if either door is opened.
  - ✓ Heavy-duty, cam-style latch seals doors tight through years of service.

- Productivity**
- ✓ Unique Air Logic system (pilot actuated) to maximize air flow to the nozzle.
  - ✓ Double-wall, sound-insulated doors.
  - ✓ 12-gauge steel all-welded construction, with strength breaks to form a rigid, long-lasting cabinet shell.
  - ✓ Large 20" x 30" view window.

- Convenience**
- ✓ Tilt-out window, for tool-free glass changes in minutes.
  - ✓ Pressure regulator, gauge, and electric switch mounted within easy reach.
  - ✓ Built-in blow-off gun helps keep dust inside the cabinet, not on your floor.
  - ✓ Bolt-on sump pipes allow easy replacement for maintenance or conversion for use with steel media.

**BNP Blast Gun with Ceramic Nozzle**

The BNP blast gun sets the industry standards for performance, versatility, and durability. The ergonomically proven grip reduces operator fatigue and increases productivity. The standard ceramic nozzle is perfect for bead blasting, while the optional tungsten or boron carbide nozzles stand up to hundreds of hours of blasting with today's aggressive abrasives.

**Popular Accessories**

- Adjustable vortex cylinder—recommended for light weight media (std on RP collectors)
- Air-powered vertical lift door
- Alox kit (for harsh media)
- Metallic media kit
- Curtains (black or high-visibility white)
- HEPA filter (RP model only)
- Manometer kit
- Oscillator assembly
- Timed door release
- 30", 40, and 48" Dia. turntables
- Work car & track assembly
- Additional operator station
- Additional door set

# S P E C I F I C A T I O N S

## COMPLETE SYSTEM

Actual space required depends on equipment configurations, options and desired work flow. Allow additional work space for operator and maintenance access.

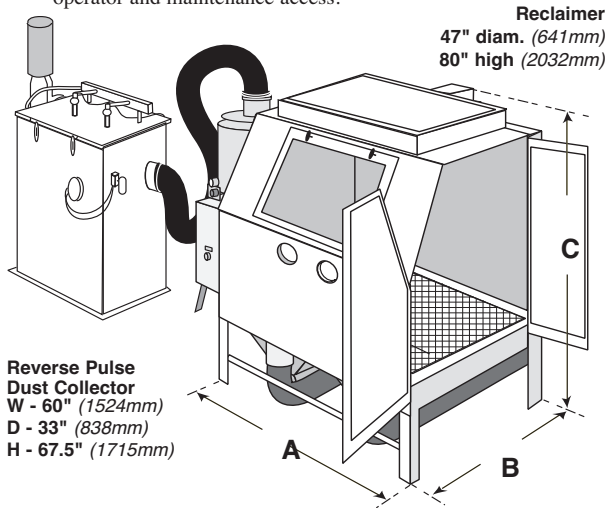

**Reclaimer**  
47" diam. (641mm)  
80" high (2032mm)

**Reverse Pulse Dust Collector**  
W - 60" (1524mm)  
D - 33" (838mm)  
H - 67.5" (1715mm)

## MEDIA RECLAIMER

### The Heart of ZERO's Blasting System

Our exclusive media reclaimers continuously extract dust and debris and return properly sized, usable media to the blast system. The standard reclaimer handles all non-metallic media. For metallic media, specify reduced ID conveying hose.

The suction blast metering valve is infinitely adjustable from fully-closed to wide open, and locks into any setting without tools.

The versatile design of our larger reclaimers lets you quickly adapt the system to your changing needs - add media hoppers, rubber liners, or pull-through dust collection.

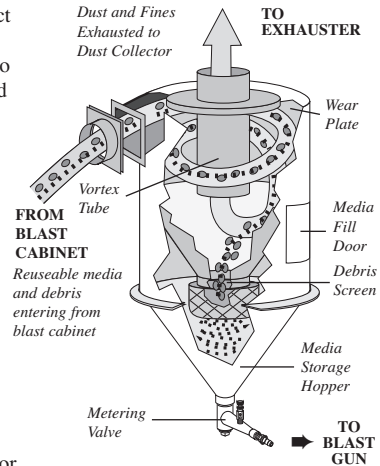

## BNP BLAST GUN

### AIR CONSUMPTION

BNP GUN	NOZZLE ORIFICE	AIR JET	CFM at 80 PSI	M <sup>3</sup> /Min at 5,5 BAR	MINIMUM RECLAIMER
No. 4	5/16"	1/8"	21	0,60	900 CFM (25 m <sup>3</sup> /m)
No. 5	5/16"	5/32"	32	0,90	900 CFM (25 m <sup>3</sup> /m)
No. 6	3/8"	3/16"	48	1,35	900 CFM (25 m <sup>3</sup> /m)
No. 7	7/16"	7/32"	62	1,76	900 CFM (25 m <sup>3</sup> /m)
No. 8	1/2"	1/4"	85	2,41	900 CFM (25 m <sup>3</sup> /m)

BNP Mini Blast Rooms are furnished with a No. 5 BNP gun. Other sizes and liner materials are available.

## ELECTRICAL

(Available with three phase motors only):

900 CFM (25 m<sup>3</sup>/m) 2HP, 3PH, 60HZ, (1.5KW, 220V, 3PH, 50HZ,);  
1200 CFM (34 m<sup>3</sup>/m) 5HP, 3PH, 60HZ, (3.7KW, 220V, 1PH, 50HZ,);

Other motors and electrical configurations are available to make your system compatible with local power systems.

## ORDERING INFORMATION

Model Number	Reclaim CFM (m <sup>3</sup> /m)	Dust Coll.	230V Stk. No.	460V Stk. No.	Ship Wt. lb(kg)
BNP-6012S-900 DF	900 (25)	Dry Filter	25475	25476	2,215 (1005)
BNP-6012S-900 RPC	900 (25)	RPC-2	25479	25480	2,495 (1132)
BNP-6012S-900 RPH	900 (25)	RPH-2	25483	25484	3,070 (1393)
BNP-6012S-1200 RPH	1200 (34)	RPH-3	25487	25488	3,825 (1735)
BNP-7212S-900 DF	900 (25)	Dry Filter	25501	25502	2,835 (1420)
BNP-7212S-900 RPC	900 (25)	RPC-2	25505	25506	3,115 (1286)
BNP-7212S-900 RPH	900 (25)	RPH-2	25509	25510	3,690 (1674)
BNP-7212S-1200 RPH	1200 (34)	RPH-3	25513	25514	4,735 (2148)

Distributed By:

## CABINET

### Working Chamber Size

<b>BNP-6012S</b>	58" wide (1473 mm) 58.5" deep (1486 mm) 53" high (1346 mm)
<b>BNP-7212S</b>	69" wide (1753 mm) 70.5" deep (1778 mm) 63" high (1600 mm)

### Window Size (safety glass)

30" wide (762 mm)  
20" high (508 mm)

Double swinging doors on right side only.  
Door interlock system conforms to U.S. government regulations.

### Door Opening

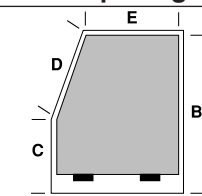

BNP6012	BNP7212
A - 55.5" (1410 mm)	67" (1702 mm)
B - 52.5" (1333 mm)	63.5" (1613 mm)
C - 27" (686 mm)	28" (711mm)
D - 27" (686 mm)	38" (965 mm)
E - 46" (1168 mm)	54" (1372 mm)

## DUST COLLECTORS

Dry filters are suitable for most industrial applications where the dust collector can be shut off periodically to shake dust from the 100% cotton sateen filter tubes.

Dry filters trap 98% of dust down to 1.0 micron.

Reverse pulse cartridge dust collectors (which trap 99.7% of dust down to 0.5 micron) allow non-stop, high-production blasting. The polyester-cellulose cartridges are automatically pulse cleaned for maximum filter efficiency. Worn cartridges can be replaced in minutes.

Dry Filters	Reverse Pulse Collector
5 sq ft filter area per tube 900 cfm DF has 40 tubes (200 sq ft)	235 sq ft filter area per cartridge RPC-2 has 2 cartridges (470 sq ft) RPH-3 has 3 cartridges (705 sq ft)

ISO 9001:2008 certified.

Clemco is committed to continuous product improvement. Specifications are subject to change without notice.

© 2012 Clemco Industries Corp. • Washington, MO 63090 • 636 239-4300 • FAX 800 726-7559

Stock No.: 20010

info@clemcoindustries.com • www.clemcoindustries.com

0991 Rev. D, 09/12